



Easy Wrap™ **FV205**
Semi automatic vertical
wrapping machine

Easy Wrap™ FV205

Semi automatic vertical wrapping machine

Features of the machine

- ◆ Long life FROMM design and construction
- ◆ Minimum of maintenance required
- ◆ Inside ring diagonal 390 mm
- ◆ Easy to operate control panel
- ◆ Manual start by a foot-switch
- ◆ Automatic cutting device for the film
- ◆ Automatic stop in zero position
- ◆ Adjustable vertical guide unit
- ◆ Frequency controlled adjustable ring speed, up to 90 rpm
- ◆ Acceleration and the deceleration speeds are controlled by inverter
- ◆ Guarding unit including limit switch
- ◆ Working height 960—870 mm
- ◆ Attractive and competitive price level
- ◆ Supply complete with CE-declaration of conformity



Technical data

Power supply	230V— 60/50Hz
Control circuit	24V—VDC
Power consumption	1,5 Kw approx.
Protection	IP 54

Film data

Film width	125 mm
Film thickness	35— 23 µm
Max. outside film roll diameter	250 mm
Inside core diameter	76 mm (3")

Air supply

Connection	R 10 / "1,2 mm
Air pressure	4 bar
Air consumption	20 nl/min

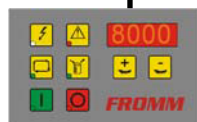

Control panel
Easy to operate control panel enables the user to operate the machine with one hand.



Door
For a very easy reload of a new film coil.

Cutting device
After the foot switch has been released, the gripper will take the film, pulls it back and cuts it automatically. The machine returns to its zero

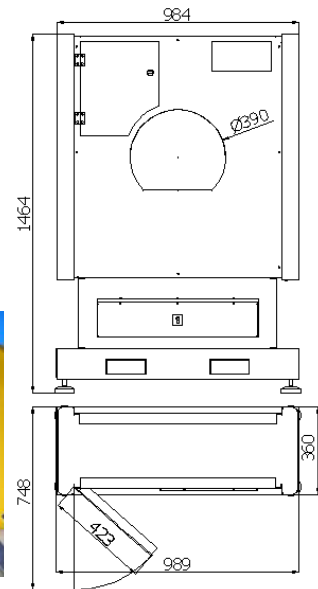

Pack details

- ◆ Max 250 x 200 mm (wxh)
- ◆ Min 30 x 30mm (wxh)
- ◆ Diagonal 390 mm
- ◆ Weight 25 kg

GS PACKAGING

مؤسسة فصول الخليج لمعدات وأدوات التغليف
GULF SEASON STRAPPING & PACKAGING SYSTEMS

Dammam Head Office: Tel: +966 (13) 847 3734 / 847 3735, Fax: +966 (13) 847 3740
Riyadh Branch: Tel: +966 (11) 438 9060, Fax: +966 (11) 438 9061
Jeddah Branch: Tel: +966 (12) 602 0241, Fax: +966 (12) 602 0167
Website: www.gspackaging.net
E-mail: sales@gspackaging.net, info@gspackaging.net