

Semi-automatic strap feeding system for plastic strapping

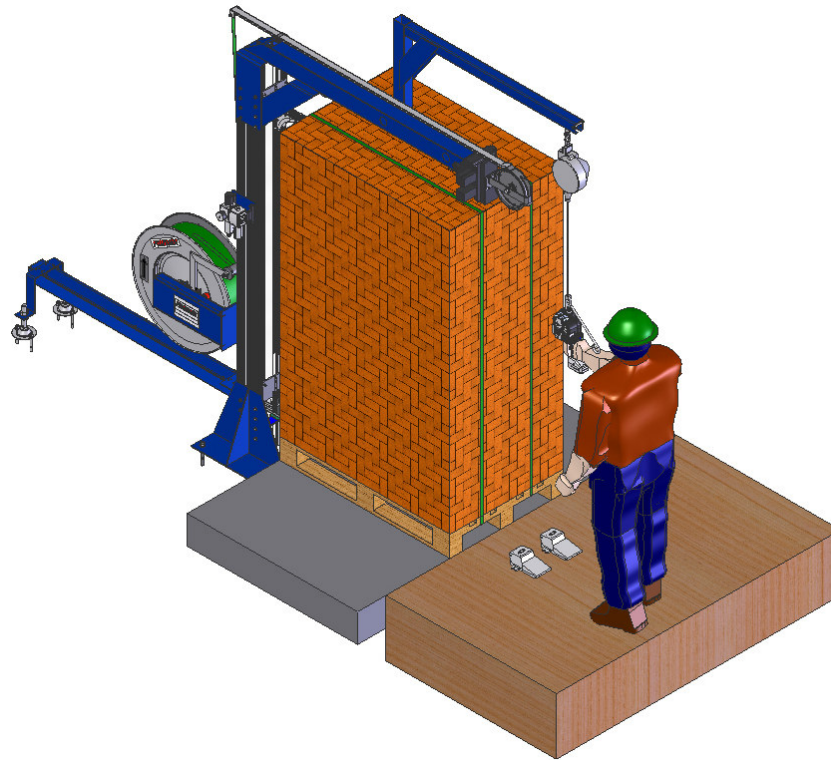

Characteristics

Max. product dimensions (standard):	W: 1200 mm, H: 1500 (2200)mm, L: ∞
Strapping qualities:	Polyester (PE T) and Polypropylene (PP) – machine grade
Strapping dimensions:	widths 12.0 – 32 mm / 1/2 – 1 1/4"
thicknesses	0.5 – 1.27 mm / 0.02 – 0.05"
Tools recommended:	P326, P327, P330, P350, P355, P356
Feeding unit:	E101 – pneumatically operated
Dispenser:	KB2 – dispenser with brake for standard strap coils (25 kg)
Longitudinal displacements:	EFB100: stationary without sword EFP200: stationary with sword EFP505: moveable with sword
Air consumption	6 Bar +/- 0,5 bar / 25NI/sek

Chart of standard types model EFB

Model	Max. product height (mm)		Longitudinal displacement		S word		Platform/ conveyor height	
	1500	2200	stationary	on rail	with	without	Standard (mm)	Special (mm)
EFP100/1500	X		X			X	390 - 510	0 - 1200
EFP100/2200		X	X			X	390 - 510	0 - 1200
EFP200/1500	X		X		X		390 - 510	0 - 1200
EFP200/2200		X	X		X		390 - 510	0 - 1200
EFP505/1500	X			X	X		0 - 120	0 - 1200
EFP505/2200		X		X	X		0 - 120	0 - 1200

Advantages

- Strap feeding systems reduce the total strapping time substantially compared to manual feeding methods
- Save labour: operators on both sides of the conveyor are no longer required
- User friendly: easy strap insert inside pallet or a round high/wide packs
- The rugged feeding systems have been designed for continuous and shift operations demanding a high working reliability
- Easy handling allows swift operation
- A wide variety of different feeding systems in standard and special dimensions are available
- Every feeding system is built for the requirement of the customer
- A suspension device with a running wagon for the strapping tool and a foot pedal to start the feeding operations are supplied with the system
- Easy installation, only pneumatically controlled
- The strap is placed with the right angle to the pack to avoid loss of strap tension
- Safety fences are not necessary in case of stationary machines

Accessories

- Strapping tool and balancer
- Lower wooden runner
- Other frame dimension for special conveyor height/ product dimensions



Dispenser KB2



Strap feeding unit E 101

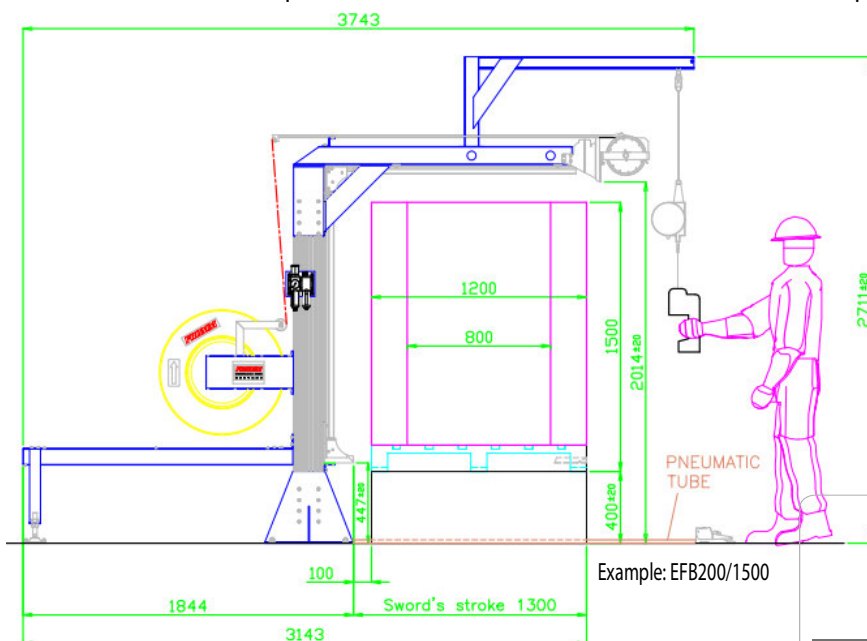

Example: EFB200/1500

GS PACKAGING
 مؤسسة فصول الخليج لمعدات وأدوات التغليف
 GULF SEASON STRAPPING & PACKAGING SYSTEMS

Dammam Head Office: Tel: +966 (13) 847 3734 / 847 3735, Fax: +966 (13) 847 3740
 Riyadh Branch: Tel: +966 (11) 438 9060, Fax: +966 (11) 438 9061
 Jeddah Branch: Tel: +966 (12) 602 0241, Fax: +966 (12) 602 0167
 Website: www.gspackaging.net
 E-mail: sales@gspackaging.net, info@gspackaging.net