

# EXC-103TB

EXC-SERIES

## SPECIFICATION

TAPE WIDTH	1 1/2", 2"
BELT SPEED	23 METERS/MINUTE
CAPACITY	(L) 120mm - □ (W) 150mm - 500mm, (H) 120mm - 500mm
POWER SUPPLY	100/110/220/230/240V., 50Hz/60Hz., 1-Phase
POWER CONSUMPTION	450W

## OPTION

3" Tape head

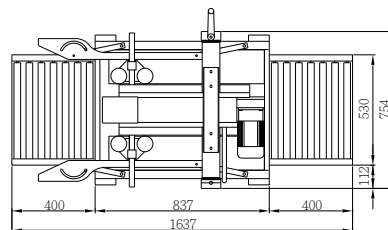
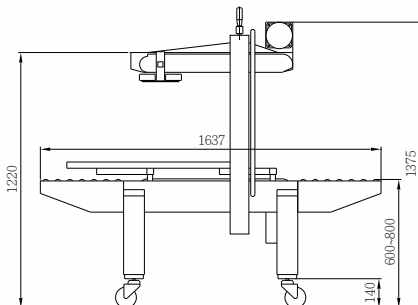

 **GS PACKAGING**

مؤسسة فصول الخليج لمعدات وأدوات التغليف  
GULF SEASON STRAPPING & PACKAGING SYSTEMS

Dammam Head Office: Tel: +966 (13) 847 3734 / 847 3735, Fax: +966 (13) 847 3740  
Riyadh Branch: Tel: +966 (11) 438 9060, Fax: +966 (11) 438 9061  
Jeddah Branch: Tel: +966 (12) 608 4832, Fax: +966 (12) 608 4835  
Website: [www.gspackaging.net](http://www.gspackaging.net)  
E-mail: [sales@gspackaging.net](mailto:sales@gspackaging.net), [info@gspackaging.net](mailto:info@gspackaging.net)