

EKT-525/630

EKT-SERIES

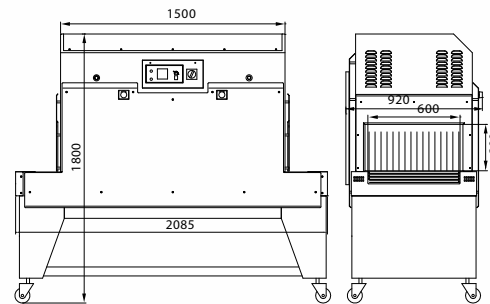
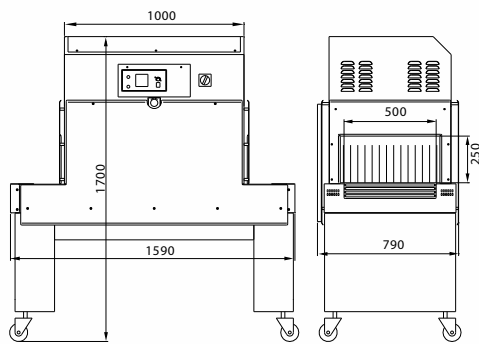

SPECIFICATION

POWER SUPPLY
MAX. POWER CONSUMPTION
TUNNEL INLET
MACHINE DIMENSION
MACHINE WEIGHT

EKT-525

220V., 60HZ., 3-PHASE ; 400V., 50HZ., 3-PHASE
9Kw
500mm (W) X 250mm (H)
1590mm (L) X 790mm (W) X 1700mm (H)
305Kg

EKT-630

220V., 60HZ., 3-PHASE ; 400V., 50HZ., 3-PHASE
18Kw
600mm (W) X 300mm (H)
2085mm (L) X 890mm (W) X 1800mm (H)
485Kg



GS PACKAGING

مؤسسة فصول الخليج لمعدات وأدوات التغليف
GULF SEASON STRAPPING & PACKAGING SYSTEMS

Dammam Head Office: Tel: +966 (13) 847 3734 / 847 3735, Fax: +966 (13) 847 3740
Riyadh Branch: Tel: +966 (11) 438 9060, Fax: +966 (11) 438 9061
Jeddah Branch: Tel: +966 (12) 608 4832, Fax: +966 (12) 608 4835
Website: www.gspackaging.net
E-mail: sales@gspackaging.net, info@gspackaging.net