

EKL-455MT

EKL-SERIES



SPECIFICATION

POWER SUPPLY	220V., 60HZ., 3-PHASE ; 400V., 50HZ., 3-PHASE
MAX. CONSUMPTION POWER	9Kw
SEALING DIMENSION	400mm (W) X 550mm (D)
TUNNEL INLET DIMENSION	400mm (W) X 200mm (H)
MAX. FILM ROLL DIMENSION	600mm X Ø3000mm
WORKING PLATE HEIGHT	900mm
MACHINE DIMENSION	2570mm (L) X 870mm (W) 1600mm (H)
MAX. PACKING HEIGHT	150mm
MACHINE WEIGHT	400Kg

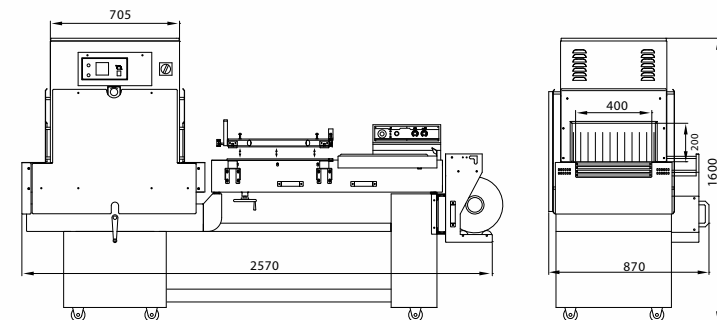

مؤسسة فصول الخليج لمعدات وأدوات التغليف
GULF SEASON STRAPPING & PACKAGING SYSTEMS

Dammam Head Office: Tel: +966 (13) 847 3734 / 847 3735, Fax: +966 (13) 847 3740
Riyadh Branch: Tel: +966 (11) 438 9060, Fax: +966 (11) 438 9061
Jeddah Branch: Tel: +966 (12) 608 4832, Fax: +966 (12) 608 4835
Website: www.gspackaging.net
E-mail: sales@gspackaging.net, info@gspackaging.net